



# TURRETMASTER Automatic Butt Splicer

MODEL S-TAB-42-16



## FEATURES...

- Very Compact Design
- Double End Roll Support
- Portability package simplifies moving machine
- Simple floor pick up rolls
- Industry Standard reliable PLC control
- Tape trimmers not required
- Slide out Tape Applicators
- Minimum material left after splice
- Ultra Solid construction
- Convenient Operation
- No connection required between splicer and parent machine
- Web break detector
- Interlock safety guarding
- Web Tension adjustable while running
- See thru festoon guarding provides better machine visibility

## OPTIONS...

- Other sizes of air shafts
- CE compliance
- Registration system for preprinted webs
- Application engineering for unique requirements

THE TURRETMASTER BUTT SPLICER IS SPECIFICALLY DESIGNED FOR TAG & LABEL APPLICATIONS

CTC INTERNATIONAL INC.

# SPECIFICATIONS

- WEB WIDTHS: 13", 16", 20", 24"
- ROLL DIAMETER: 42" STANDARD
- CORE DIAMETERS: 3"-6" AVAILABLE
- LINE SPEED: 500 FPM STANDARD, HIGHER SPEEDS AVAILABLE
- ELECTRICAL: 220 VOLTS, THREE PHASE 50/60 HZ
- PNEUMATIC: 80 PSI 3/8" LINE NEGLIGIBLE AIR CONSUMPTION

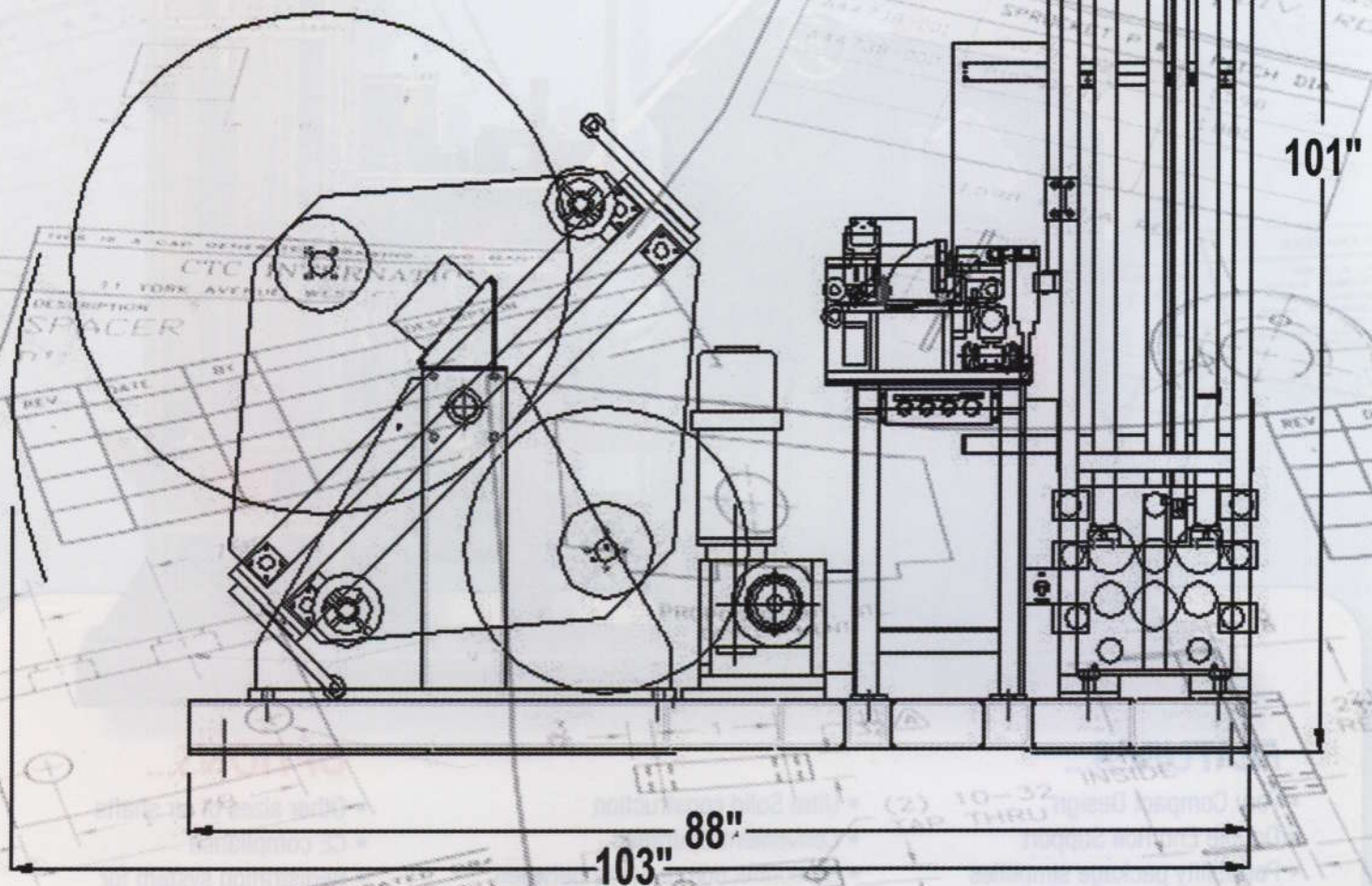

**INTERNATIONAL INC.**

11 York Avenue, West Caldwell, New Jersey 07006

Phone: 973-228-2300 / Fax 973-228-7076

Email: [info@ctcint.com](mailto:info@ctcint.com) / [www.ctcint.com](http://www.ctcint.com)