

PREMIER-SD 20/20

Inspection - Slitter - Rewinder



The PREMIER-SD 20/20 combines our multi-motor Servo Drive web transport technology with our patented Shuttle Retrieval system to provide bidirectional inspection, fault editing and re-inspection of high value added or security sensitive products—all in a single pass.

Standard Features (in addition to standard Premier-SD features):

- Additional tabletop web guide with integrated adjustable splicing table and diaphragm pneumatic web clamps
- Position for Vision Inspection System
- Patented Shuttle Retrieval System



100% Vision Inspection



Patented Shuttle Retrieval System with Web Guide & Vision Position

Specifications

Web Width	330 mm (13") 407 mm (16")
Maximum Unwind Diameter	760 mm (30")
Maximum Rewind Diameter	457 mm (18") Optional 610 mm (24")
Maximum Speed	285 m/min (935 ft/min)
Unwind/Rewind Shaft Diameter	76.2 mm (3") (other sizes available)
Electrical	220V, Three Phase 50/60 Hz (optional 400V)
Air	5-7 bars (80-100 PSI) Nominal Consumption
Dimensions (L x D x H)	3835 x 1245 x 2260 mm 151" x 46" x 89" 3835 x 1321 x 2260 mm 151" x 52" x 89"
Weight	Approx 1200-1400 kgs (2650-3100 lbs)

arpeco[®]

A PRECISION AUTOMATION[®] COMPANY

Manufacturing - 1841 Old Cuthbert Road Cherry Hill, NJ USA Phone: 856-428-7400 Fax: 856-428-1270
International Sales & Service - 7405 East Danbro Crescent Mississauga ON, Canada L5N 6P8
Phone: 905-812-5150 Fax: 905-812-5171

Visit our website at www.arpeco.com

PREMIER-SD 20/20

Inspection - Slitter - Rewinder

Options

To handle a wide variety of applications we offer the following options:

- Hydraulic Unwind Roll Lift
- Stroboscopes
- Clear/Transparent Label Count
- Flag/Millsplice and Matrix & Missing Label Detection
- 100% Vision Inspection Integration
- Motor-driven Waste Rewind
- Fixed / Cartridge Shear Slitting with additional Cartridges and setup devices
- Score or Razor or Lineal Die Slitting
- Trim Extraction
- Ironing and Bowed Rollers
- Table-top Web Guide and Ultrasonic Edge Sensors
- Label Remover or Lead & Tail Entry Systems
- Flanged Shafts & Adaptors



305mm (12") Color Touchscreen

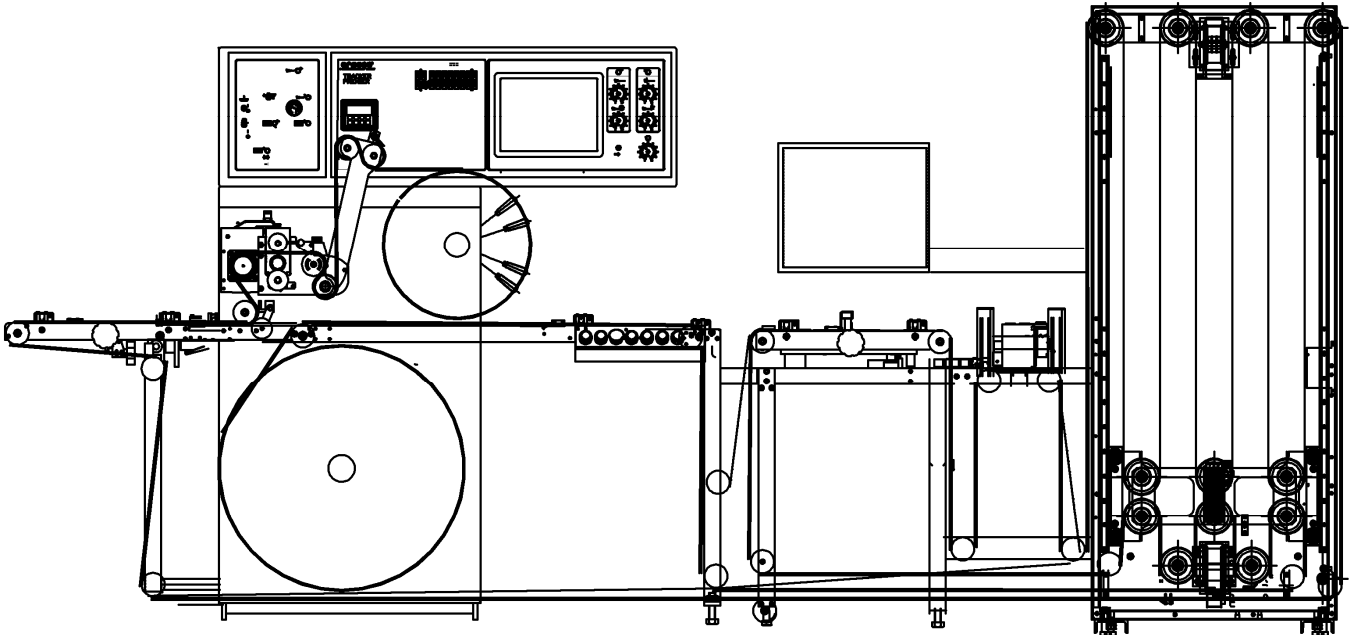

Manufacturing - 1841 Old Cuthbert Road Cherry Hill, NJ USA Phone: 856-428-7400 Fax: 856-428-1270
International Sales & Service - 7405 East Danbro Crescent Mississauga ON, Canada L5N 6P8
Phone: 905-812-5150 Fax: 905-812-5171

Visit our website at www.arpeco.com

arpeco[®]

A PRECISION AUTOMATION[®] COMPANY